

THE PRODUCTION
DRILLING SOLUTION

AutoDrill™

Multiple Spindle Drilling Heads

AutoDrill multiple spindle drilling heads are designed for use with our self-feed drilling equipment. They feature:

- Wide Range Adjustment
- Industry Standard “ER” High Precision Collet System
- Quiet, Efficient Helical Gearing
- Spindle Scales for Easy Setup
- Full Bearing Construction for Long Service
- Collet Wrench
- Center to Center Distances as Close as .53"
- Capacity to 5/8" in Steel
- Compact Profile for Tight Spacing
- Short Overhang for Reduced Spindle Loads*
- All Position Mounting

Options

- Custom Setup Fixtures
- Rod Guides
- Drill Press Adapters

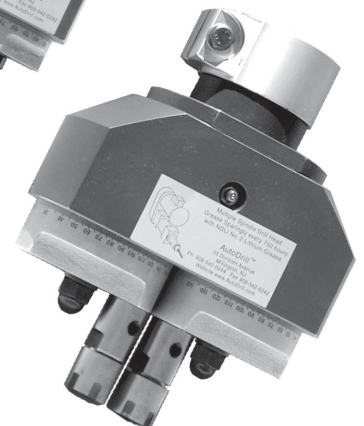
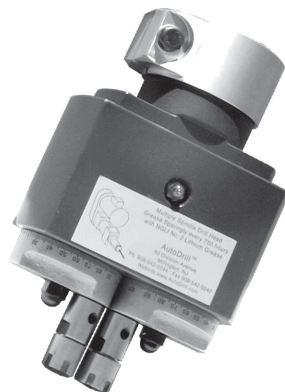
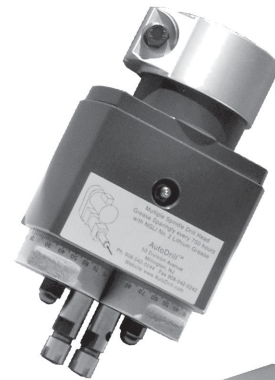
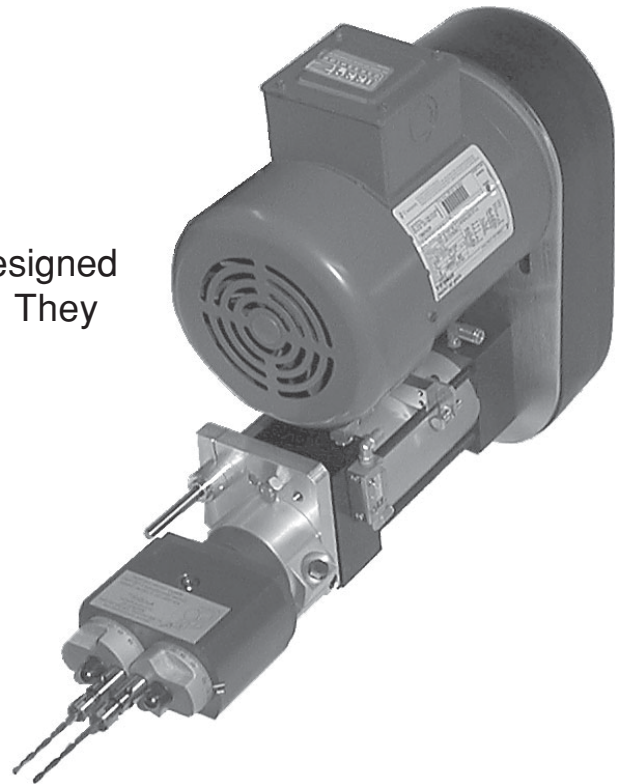

* Tooling, whenever possible, should be operated in drill bushings for proper precision and support.

Specifications - Adjustable Spindle Drill Heads

ADJUSTABLE TWO SPINDLE DRILL HEAD

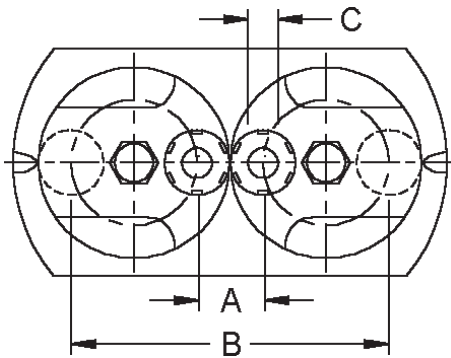

MODEL	A (MIN C-C)		B (MAX C-C)		C (MAX DIA)	
	in	mm	in	mm	in	mm
2-5	.532	13.5	2.89	73.5	3/16	5
2-7	.71	18	3.54	90	1/4	7
2-10	.867	22	4.17	106	3/8	10
2-16	1.42	36	6.45	164	5/8	16

ADJUSTABLE IN-LINE THREE SPINDLE DRILL HEAD

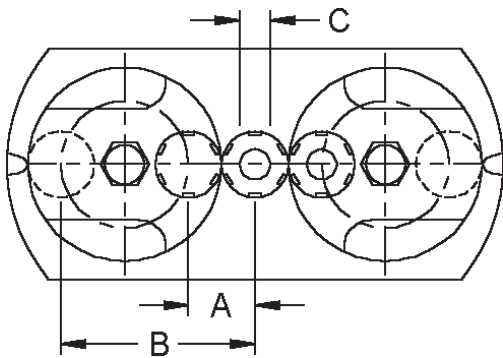

MODEL	A (MIN C-C)		B (MAX C-C)		C (MAX DIA)	
	in	mm	in	mm	in	mm
3L-5	.552	14	1.73	44	3/16	5
3L-7	.788	20	2.20	56	1/4	7
3L-10	.867	22	2.52	64	3/8	10
3L-16	1.42	36	3.93	100	5/8	16

ADJUSTABLE BOLT CIRCLE THREE SPINDLE DRILL HEAD

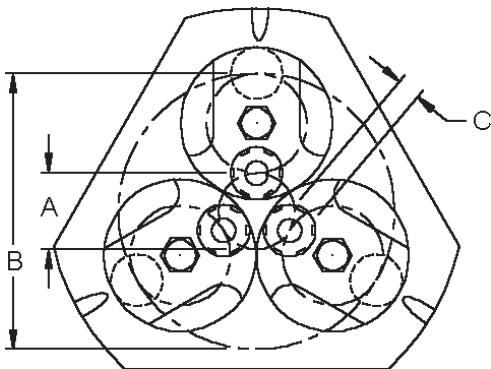

MODEL	A (MIN C-C)		B (MAX C-C)		C (MAX DIA)	
	in	mm	in	mm	in	mm
3C-5	.887	22	3.22	82	3/16	5
3C-7	1.10	28	3.93	100	1/4	7
3C-10	1.26	32	4.56	116	3/8	10
3C-16	2.04	52	7.08	180	5/8	16

ADJUSTABLE BOLT CIRCLE FOUR SPINDLE DRILL HEAD

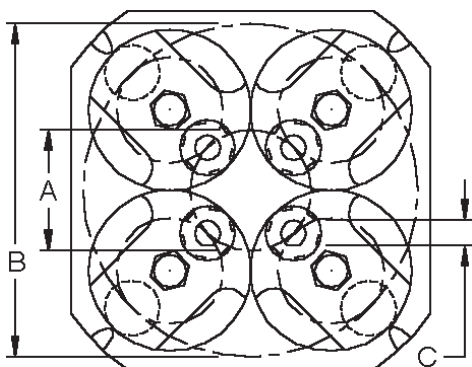

MODEL	A (MIN C-C)		B (MAX C-C)		C (MAX DIA)	
	in	mm	in	mm	in	mm
4C-5	1.33	34	3.70	94	3/16	5
4C-7	1.65	42	4.48	114	1/4	7
4C-10	1.89	48	5.19	132	3/8	10
4C-16	3.07	78	8.11	206	5/8	16

AutoDrill™

50 Division Avenue Millington, NJ 07946 Ph. 800-871-5022 Fax 908-542-0242
 Website www.AutoDrill.com E-Mail Info@AutoDrill.com